



AMERICAN
BUILDING
COMPONENTS

5V CRIMP

Technical/Installation Information

IMPORTANT NOTICE

READ THIS MANUAL COMPLETELY PRIOR TO BEGINNING THE INSTALLATION OF THE 5V CRIMP PANEL SYSTEM.

ALWAYS INSPECT EACH AND EVERY PANEL AND ALL ACCESSORIES BEFORE INSTALLATION. NEVER INSTALL ANY PRODUCT IF ITS QUALITY IS IN QUESTION. NOTIFY ABC IMMEDIATELY IF ANY PRODUCT IS BELIEVED TO BE OUT OF TOLERANCE, SPECIFICATION OR HAS BEEN DAMAGED DURING SHIPMENT.

IF THERE IS A CONFLICT BETWEEN PROJECT ERECTION DRAWINGS PROVIDED OR APPROVED BY THE MANUFACTURER AND DETAILS IN THIS MANUAL, PROJECT ERECTION DRAWINGS WILL TAKE PRECEDENCE.

The Engineering data contained herein is for the expressed use of customers and design professionals. Along with this data, it is recommended that the design professional have a copy of the most current version of the North American Specification for the Design of Cold-Formed Steel Structural Members published by the American Iron and Steel Institute to facilitate design. This Specification contains the design criteria for cold-formed steel components. Along with the Specification, the designer should reference the most current building code applicable to the project jobsite in order to determine environmental loads. If further information or guidance regarding cold-formed design practices is desired, please contact the manufacturer.

Descriptions and specifications contained herein were in effect at the time this publication was approved for printing. In a continuing effort to refine and improve products, ABC reserves the right to discontinue products at any time or change specifications and/or designs without incurring obligation. To ensure you have the latest information available, please inquire or visit our website at abcmetalroofing.com. Application details are for illustration purposes only and may not be appropriate for all environmental conditions, building designs, or panel profiles. Projects should be engineered to conform to applicable building codes, regulations, and accepted industry practices. Insulation is not shown in these details for clarity.

For complete performance specifications, product limitations, and disclaimers, please consult ABC's Paint and Galvalume Plus® warranties. Upon receipt of payment in full, these warranties are available upon request for all painted or Galvalume Plus® prime products. Sample copies can be found at abcmetalroofing.com or contact your local ABC Sales Representative.

TABLE OF CONTENTS

PRODUCT INFORMATION

Application, Storage and Handling Information	V-4 - V-5
Architect/Engineer Information	V-6
General Description	V-7
UL 90 Construction Numbers	V-8
Section Properties	V-9
Product Checklist	V-10
Fastener Patterns	V-11

DETAILS

Ridge	V-12
Endlap	V-13
Valley	V-14
Hip	V-15
Rake	V-16
Eave	V-17
Gutter	V-18
Slope Change	V-19

PRODUCT INFORMATION

APPLICATION, STORAGE AND HANDLING INFORMATION

SAFETY PRECAUTIONS

Improper unloading and handling of bundles and crates may cause bodily injury or material damage. Use extreme care in the operation of power lifting devices such as cranes and forklifts and follow the safety instructions provided by their manufacturer. Crates, boxes and bundles may be bulky, heavy, or both. The improper or unaided lifting of them may cause bodily injury. The manufacturer is not responsible for bodily injuries or material damage due to improper handling during unloading, storage, or job site placement.

Protective heavy duty gloves should be worn when handling metal panels and trim products. Safety goggles or face shield should be worn while cutting or drilling metal products with power tools. Follow the safety instructions provided by the manufacturer of the power tools.

Use extreme care when walking, sitting, standing, or kneeling on a metal roof to avoid a fall. Galvalume® and galvanized panels have a light coating of oil to protect the panels from moisture prior to erection.

They can be extremely slippery, as are painted panels, when they are wet. If necessary, remove the oil coating with a non-abrasive detergent and water mixture followed by a clear water rinse. Insure the panels are dry prior to installation.

STORAGE AND HANDLING

To preserve and protect the attractive appearance of ABC's roofing and siding from damage caused by moisture, corrosive chemicals or improper handling, it is necessary that you take a few simple precautions. When material is received bundled, panels should be inspected for moisture. If there is moisture, the panels should be separated and dried. If shipping damage is found, the carrier should be advised and a notation made on the bill of lading.

On job sites, reasonable care should be taken when handling painted surfaces during installation in order to protect the finish. Although the paint coating is tough and provides impact resistance, dragging panels across the surface of one another will almost certainly mar the finish.

Prolonged storage of sheets in bundles is not recommended. If conditions do not permit immediate erection, extra care must be taken to protect the material from damage caused by moisture.

Store bundled sheets ONLY IN A DRY PLACE. Sheets should be unbundled, stood on end against an interior wall to allow for air circulation. If unable to store sheets in an upright position, strapping bands should be broken and sheets should be blocked off the floor with one end slightly elevated. Stacked sheets should then be completely protected from the elements while maintaining good airflow to prevent condensation. A properly draped canvas tarpaulin, that allows air flow, is an example of a good protective cover. Do not use plastic as it causes sweating or condensation to occur.

BUILDING DESIGN AND CONSTRUCTION

It is important to protect metal panels from potentially corrosive situations and materials. This will insure the good performance and long life of the metal. If installing metal panels over green lumber, damp lumber, or treated lumber (CCA or ACQ), a barrier must be installed to separate the wood from the metal. A barrier may be formed with plastic or other suitable material. Avoid contact with, or water runoff from, dissimilar metals such as copper, lead or graphite. Dissimilar metals under the roof panels may be separated with asphalt, builders felt, caulking compounds or gasket material.

Metal panels must further be protected from contact with strong chemicals such as fertilizers, lime acids, animal waste and soil. All of these have the potential to initiate corrosion in metal panels. Metal panels should not be in permanent contact with soil.

Temperature variations, (dew point) between the outside air and the interior building air mass can cause condensation to occur on the inside of the building on the panel's surfaces. Proper venting and air flow consideration and the use of a vapor barrier such as vinyl backed insulation can eliminate this problem. If left unattended, condensation can cause the premature degradation of the metal and void any applicable warranties. For information on this subject, please refer to MCA's white paper on controlling condensation in steep slope metal roofing systems.

The substructure, on which the panels are to be installed, must be "on plane" (1/4" tolerance) from eave to ridge. Maximum recommended panel length is 36'; minimum panel length is 3'.

PRODUCT INFORMATION

APPLICATION, STORAGE AND HANDLING INFORMATION

VENTILATION

Sufficient air movement should be provided by means of a ridge or rotary vent, power operated fans, or other openings to minimize condensation. Contact the equipment manufacturer for specific information or a qualified mechanical engineer.

ROOFING INSTALLATION

Check substructure for proper alignment and uniformity to avoid panel distortion. ABC recommends the use of 5/8" plywood for the substructure. Minimum 5/8" plywood substructure is MANDATORY for UL 90 Uplift Rating.

THE MINIMUM roof slope recommended is 3 inches of rise per foot. This ensures that sufficient slope is present for adequate drainage. The panels must be installed over a completely water-proofed substructure.

It is important to remember that in the installation of roof sheets, the sidelaps should face away from the direction of the prevailing wind. The first sheet should be installed square with the eave and at the down-wind end of the roof, farthest from the direction of the wind.

For proper fastener application, refer to our published guide.

Remember to sweep the roof clean of any metal filings created from fastener placement or cutting of panels to prevent rust marks on the surface of the painted panels.

Installing Slimline® panels over an uneven substrate will cause distortion of the panel. It is the responsibility of the installer to insure a suitable substrate prior to panel application. Distortion in the panel caused by an uneven substrate, ripples or laps in the vapor barrier, debris, etc., are not defects in the material, and are not the responsibility of ABC. Slimline® panels cannot be endlapped.

CLOSURES AND SEALANTS

To thoroughly protect the contents of any structure from moisture, regardless of building size or roof slope, closure strips should be used at the roof ridge, hip and eave. For maximum protection, all caulking used should be urethane. **Silicone caulks are not recommended for panels or trims.**

CUTTING METAL PANELS

ABC recommends the use of power shears or nibblers that can follow the contour of the panel's profile. While not recommended, if a power saw is to be used, you must use a blade designed to cut the metal at a low temperature to prevent melting of the Galvalume® coating, such as the Slasher® from Dynamic Fasteners. You should protect the panel during the cutting process to prevent marring the panel surface. Panels should be thoroughly brushed after cutting to remove any particles of metal and caution should be taken that filings from cutting don't settle on other panels. Follow the safety instructions provided by the manufacturer when using any tools.

PANEL SELECTION

ABC's bare Galvalume® (Galvalume Plus®), and color coated products are produced from material that meets or exceeds the specifications outlined in ASTM-792.

If you chose a bare Galvalume® (Galvalume Plus®), for your application you should be aware that this product is recommended for applications where aesthetic appearance is not your prime concern. Unpainted products may not weather uniformly and while they may be shiny and bright when new, they will fade or "patina" with age. Acid rain and other corrosive atmospheres, as well as the accumulation of airborne debris and dirt will affect this aging process and the products' appearance.

If aesthetic appearance is one of your concerns, ABC recommends you choose one of our many color coated panel selections. Copies of ABC's color coated panel warranty are available at your point of purchase, or from the ABC office located nearest to you.

PRODUCT INFORMATION

ARCHITECT/ENGINEER INFORMATION

1. Minimum recommended slope is 3:12. For slopes less than 3:12, call ABC.
2. Use a properly aligned and uniform substructure to avoid panel distortion. Typical substructure - $\frac{5}{8}$ " plywood; alternate substructure metal or wood stringers. Spacing of stringers to be determined by load tables. For illustration purposes, details are shown over plywood.
3. 5V Crimp panels are water shedding panels and therefore must be installed on a minimum 3:12 roof slope. The panels must be installed over a completely waterproofed substructure. If the waterproof membrane is mechanically attached with metal fasteners of any type, fasteners should be covered to protect the back side of the roof panels. Any mechanical attachment device that does not lay flat on the deck will telegraph through the panels.
4. Panels are subject to surface distortion due to improperly applied fasteners. Overdriven fasteners will cause stress and induce oil canning across the panel at or near the point of attachment. Oil canning is not a cause for rejection.
5. For proper fastener application, see Product Checklist.
6. For continuous panels over 25', please inquire. Panels may be endlapped.
7. All panel ends must be sealed at eave and valley conditions. Refer to Pages V-11, V-14 and V-15 for end sealant details.
8. Fastener spacings across the width of the panel are shown on Page V-7. For fastener spacings along the length of the panel, use the wind load table on Page V-5 in conjunction with the governing code.

CAUTION

Most of the 5V Crimp load tables indicate panels can obtain a 20# live load on 2'-6" centers when installed over stringers. Please keep in mind these are uniform live loads and will not support a 200 pound man standing on one square foot. From an erectability and industry standard point of view, it is recommended that you should not span the panels more than 2'-6".

PRODUCT INFORMATION

GENERAL DESCRIPTION

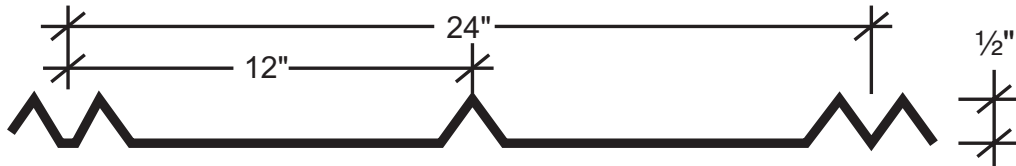

Coverage Width - 24"

Minimum Slope - 3:12

Panel Attachment - Wood screws

Panel Substrate - Galvalume Plus®

Gauges - 32, 29 or 26

Finishes - Smooth or Embossed

Coating - Galvalume Plus®, Signature 200® (Siliconized Polyester), G-40 Galvanized

PRODUCT SELECTION CHART

Product	Galvalume Plus	Galvalume Plus	Signature 200
5V Crimp	29	26	26
24" Wide	●	●	●

● - Available in any quantity.

PRODUCT INFORMATION

UL 90 Requirements 5V Crimp Construction # 453

1. Metal Panels (26 gauge) – 24" wide, continuous over two or more spans.
2. Fastener spacing along the length of the panel is 3 feet on center.
3. Fasteners – No.14-10 x 1½" Type A, Hex Head with separate ⅝ in. O.D. steel washer and a bonded neoprene washer. Fastener spacing is as follows: a line of fasteners is to be installed adjacent to the double "V" in the middle of the panel for a total of four fasteners across the width of the panel. Fastener spacing along the length of the panel is 3 feet on center.

FIRE RESISTANCE RATING

The panel qualifies for a Class A fire rating when installed over a non-combustible substrate in compliance with Underwriters Laboratories Standard UL-263. Panels installed over combustible substrate will qualify for a Class C Fire Rating only.

IMPACT RESISTANCE

The 5V panels carry a Class 4 rating under UL-2218 "Test Standard For Impact Resistance".

For UL 90 Rated Roofs, the above requirements must be followed. See UL Roofing Materials and Systems Directory for additional requirements. If you have any questions, call ABC before proceeding.

State of Florida Approval Numbers: FL#11903.1

Miami Dade County NOA: 11-0810.10, see special installation instructions, miamidade.gov.

PRODUCT INFORMATION

5V CRIMP 24" Coverage

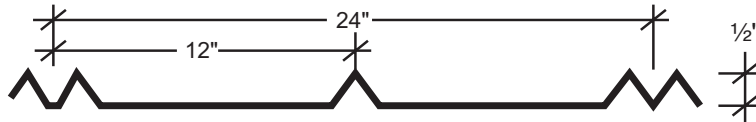

SECTION PROPERTIES								
PANEL	F _y	WEIGHT	NEGATIVE BENDING			POSITIVE BENDING		
			I _{xe}	S _{xe}	Maxo	I _{xe}	S _{xe}	Maxo
GAUGE	(KSI)	(PSF)	(IN.4/FT.)	(IN.3/FT.)	(KIP-IN.)	(IN.4/FT.)	(IN.3/FT.)	(KIP-IN.)
29	60 *	0.60	0.0011	0.0045	0.161	0.0022	0.0060	0.285
26	60 *	0.95	0.0016	0.0063	0.225	0.0030	0.0081	0.386

* F_y is 80-ksi reduced to 60-ksi in accordance with the 2012 edition of the North American Specification For Design Of Cold-Formed Steel Structural Members - A2.3.2.

Notes:

- All calculations for the properties of 5V Crimp panels are calculated in accordance with the 2012 edition of the North American Specification for the Design of Cold-Formed Steel Structural Members.
- I_{xe} is for deflection determination.
- S_{xe} is for bending.
- Maxo is allowable bending moment.
- All values are for one foot of panel width.

ALLOWABLE UNIFORM LOADS IN POUNDS PER SQUARE FOOT

29 Gauge (0.0133"), F _y = 60 ksi, F _u = 61.5 ksi								
SPAN TYPE	LOAD TYPE	SPAN IN FEET						
		1.0	1.5	2.0	2.5	3.0	3.5	4.0
1-span	NEGATIVE WIND LOAD	107.04	47.57	26.76	17.13	11.89	8.74	6.41
	LIVE LOAD/DEFLECTION	130.26	57.28	24.17	12.37	7.16	4.51	3.02
2-span	NEGATIVE WIND LOAD	162.81	78.38	45.49	29.56	20.70	15.29	11.74
	LIVE LOAD/DEFLECTION	101.37	46.40	26.38	16.97	11.82	8.70	6.67
3-span	NEGATIVE WIND LOAD	167.25	74.33	41.81	26.76	18.58	13.65	10.45
	LIVE LOAD/DEFLECTION	123.94	57.39	32.78	21.13	13.61	8.57	5.74
4-span	NEGATIVE WIND LOAD	173.39	77.06	43.35	27.74	19.27	14.15	10.84
	LIVE LOAD/DEFLECTION	116.57	53.77	30.66	19.75	13.76	9.10	6.09

26 Gauge (0.0181"), F _y = 60 ksi, F _u = 61.5 ksi								
SPAN TYPE	LOAD TYPE	SPAN IN FEET						
		1.0	1.5	2.0	2.5	3.0	3.5	4.0
1-span	NEGATIVE WIND LOAD	150.26	66.78	37.57	24.04	16.70	12.27	9.39
	LIVE LOAD/DEFLECTION	224.74	77.61	32.74	16.76	9.70	6.11	4.09
2-span	NEGATIVE WIND LOAD	220.22	106.12	61.62	40.05	28.05	20.72	15.91
	LIVE LOAD/DEFLECTION	141.66	65.00	36.99	23.80	16.58	12.20	9.35
3-span	NEGATIVE WIND LOAD	234.79	104.35	58.70	37.57	26.09	19.17	14.67
	LIVE LOAD/DEFLECTION	172.89	80.32	45.93	29.63	18.33	11.54	7.73
4-span	NEGATIVE WIND LOAD	243.40	108.18	60.85	38.94	27.04	19.87	15.21
	LIVE LOAD/DEFLECTION	162.72	75.27	42.97	27.70	19.31	12.25	8.21







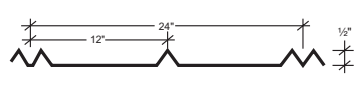
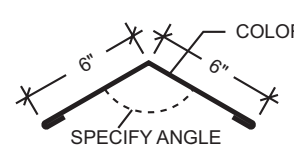
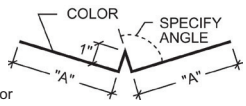
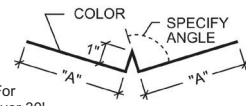
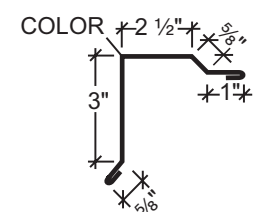
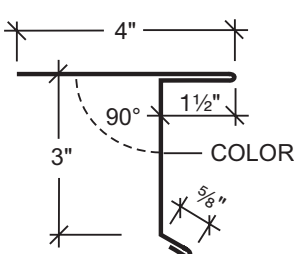
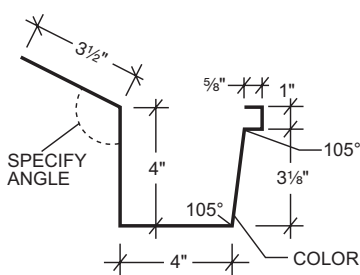
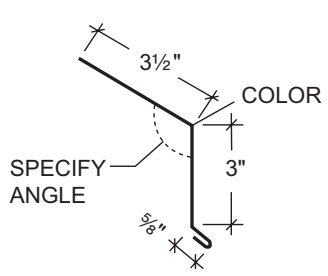

Notes:

- Strength calculations based on the 2012 AISI Standard "North American Specification for the Design of Cold-formed Steel Structural Members."
- Allowable loads are applicable for uniform loading and spans without overhangs.
- LIVE LOAD/DEFLECTION load capacities are for those loads that push the panel against its supports. The applicable limit states are flexure, shear, combined shear and flexure, web crippling at end and interior supports, and a deflection limit of L/180 under strength-level loads.
- NEGATIVE WIND LOAD capacities are for those loads that pull the panel away from its supports. The applicable limit states are flexure, shear, combined shear and flexure, and a deflection limit of L/60 under 10-year wind loading.
- Panel pullover and Screw pullout capacity must be checked separately using the screws employed for each particular application when utilizing this load chart.
- Effective yield strength has been determined in accordance with section A2.3.2 of the 2012 NAS specification.
- The use of any accessories other than those provided by the manufacturer may damage panels, void all warranties and will void all engineering data.
- This material is subject to change without notice. Please contact ABC for most current data.

The Engineering data contained herein is for the expressed use of customers and design professionals. Along with this data, it is recommended that the design professional have a copy of the most current version of the North American Specification for the Design of Cold-Formed Steel Structural Members published by the American Iron and Steel Institute to facilitate design. This Specification contains the design criteria for cold-formed steel components. Along with the Specification, the designer should reference the most current building code applicable to the project jobsite in order to determine environmental loads. If further information or guidance regarding cold-formed design practices is desired, please contact the manufacturer.

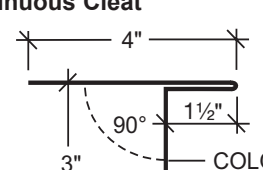
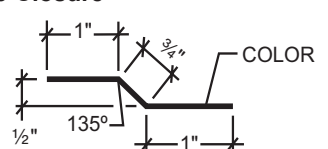
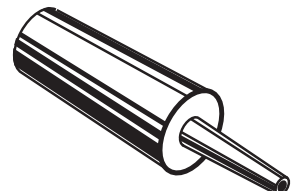
DETAILS

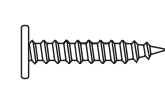
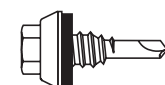
PRODUCT CHECKLIST

<p>5V Crimp Panel</p>  <p><input type="checkbox"/> Specify Roof Pitch</p> <p style="text-align: right;">AG-202 <input type="checkbox"/></p>	<p>Ridge/Hip</p>  <p><input type="checkbox"/> Specify Roof Pitch</p> <p style="text-align: right;">AG-202 <input type="checkbox"/></p>	<p>Valley</p>  <p>Standard - For valley runs under 30'</p> <p style="text-align: right;">AG-238 <input type="checkbox"/></p>  <p>Extended - For valley runs over 30'</p> <p><input type="checkbox"/> Specify Roof Pitch</p> <p style="text-align: right;">AG-239 <input type="checkbox"/></p>
<p>Rake Trim</p>  <p style="text-align: right;">AG-250 <input type="checkbox"/></p>	<p>Drip Edge</p>  <p style="text-align: right;">AG-279 <input type="checkbox"/></p>	<p>Box Gutter</p>  <p><input type="checkbox"/> Specify Roof Pitch</p> <p style="text-align: right;">AG-242 <input type="checkbox"/></p>
<p>Eave Trim</p>  <p style="text-align: right;">AG-246 <input type="checkbox"/></p>	<p>Outside Closure</p>  <p style="text-align: right;">HW-452 <input type="checkbox"/></p> <p>Inside Closure</p>  <p style="text-align: right;">HW-450 <input type="checkbox"/></p>	<p>Tri-Bead Tape Sealer</p>  <p style="text-align: right;">HW-504 <input type="checkbox"/></p> <p>Triple Bead Tape Sealer</p>  <p style="text-align: right;">HW-502 <input type="checkbox"/></p>
<p>Continuous Cleat</p>  <p style="text-align: right;">FL-338 <input type="checkbox"/></p> <p>Zee Closure</p>  <p style="text-align: right;">AG-274 <input type="checkbox"/></p>	<p>Urethane Tube Sealant</p>  <p style="text-align: right;">White HW-540 <input type="checkbox"/></p>	<p>Fastener #9 10 x 1 1/2" Long Life Wood Fastener <input type="checkbox"/></p>  <p>Fastener #13 10 x 1" Pancake Head <input type="checkbox"/></p>  <p>Fastener #4 14 x 7/8" Long Life Lap Tek <input type="checkbox"/></p>  <p>Fastener #14 1/8 x 3/16" Pop Rivet Stainless Steel <input type="checkbox"/></p> 

DETAILS

FASTENER PATTERNS

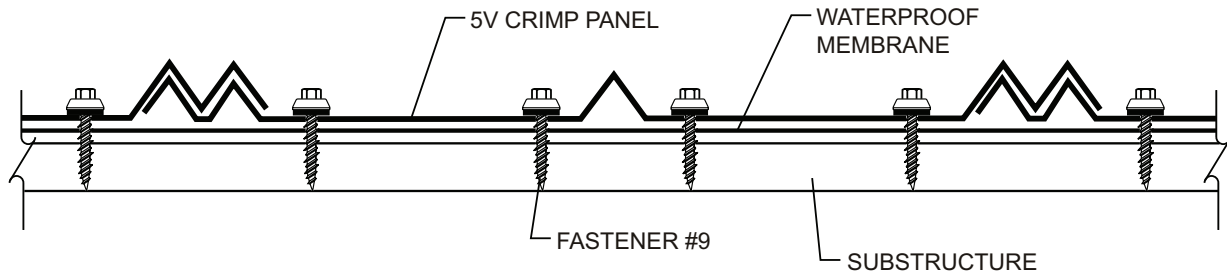

FASTENER PATTERN AT EAVE AND ENDLAP

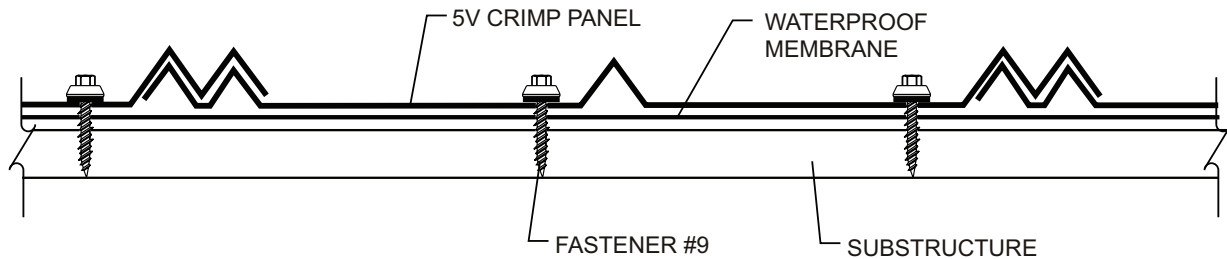

FASTENER PATTERN AT INTERIOR OF PANEL

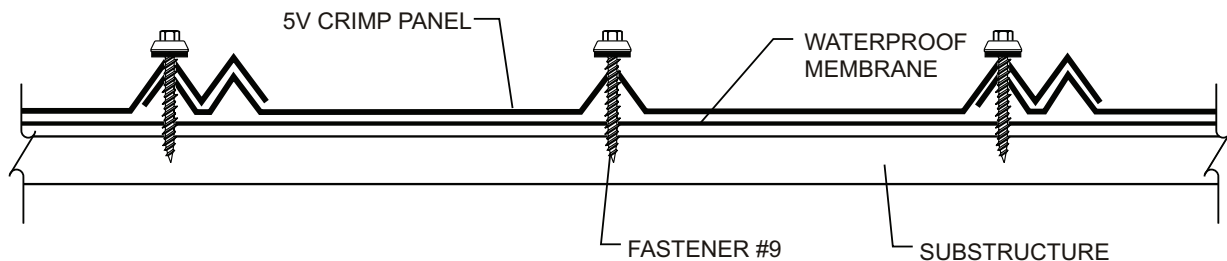

ALTERNATE FASTENER PATTERN

DETAILS

TYPICAL DETAILS RIDGE

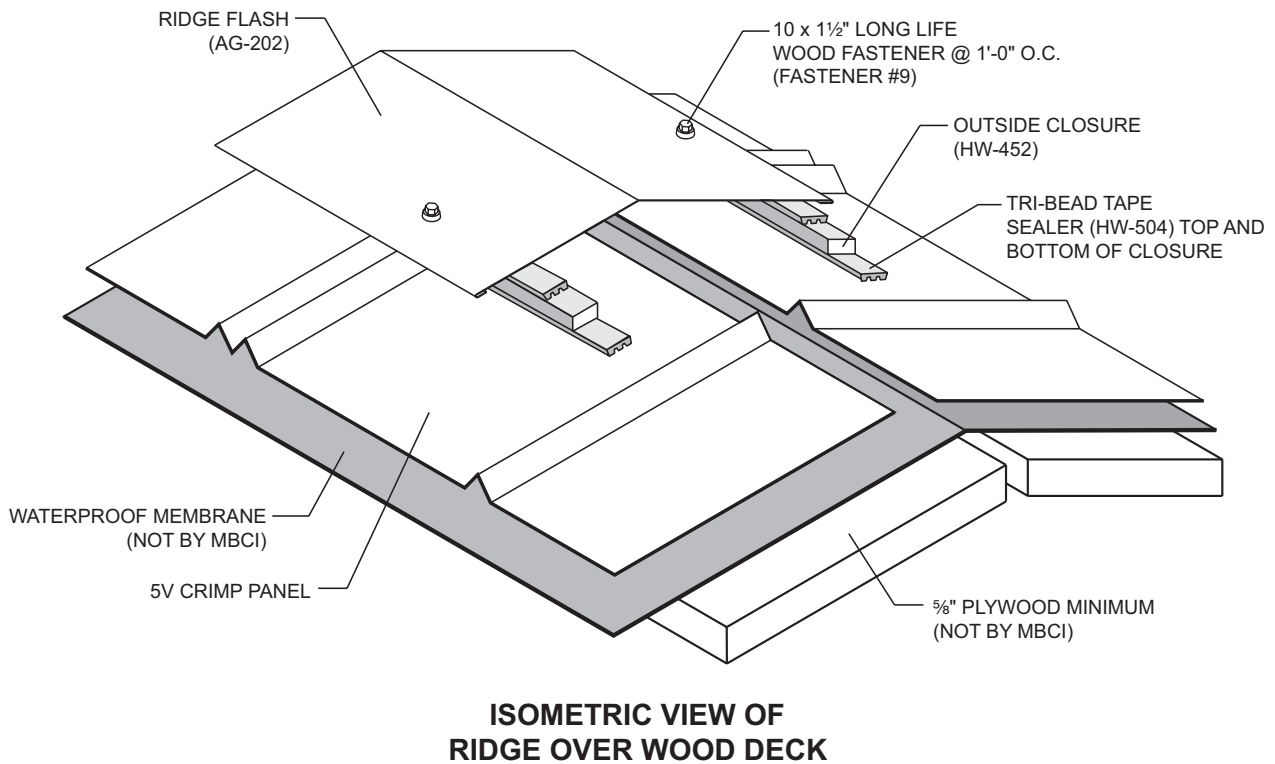
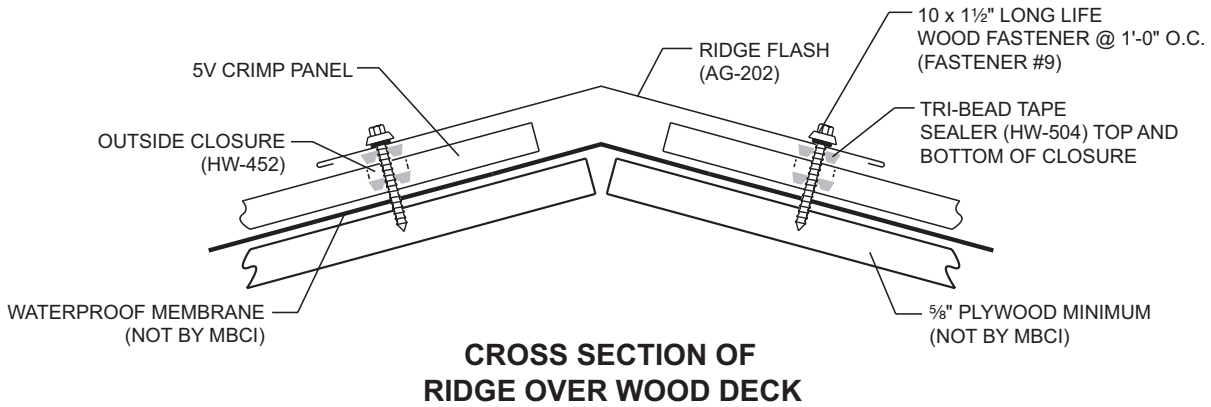

NOTE:

1. Stop panels 2" from center line of ridge.
2. Install first row of fasteners across panel to substrate 1'-0" down from bottom edge of ridge trim and space 1'-0" O.C.
3. Install Tri-Bead tape sealer across width of panels. Top edge of tape sealer is 1 3/4" from top edge of panel. Install outside closures on top of Tri-Bead tape sealer. Install additional run of tape sealer on top of outside closure.
4. Attach ridge flash with Fastener #9 (10 x 1 1/2" Long Life Wood Fastener) 1'-0" O.C. Install fasteners at each "V" in the panel to avoid dimpling the ridge flash.

DETAILS

TYPICAL DETAILS ENDLAP

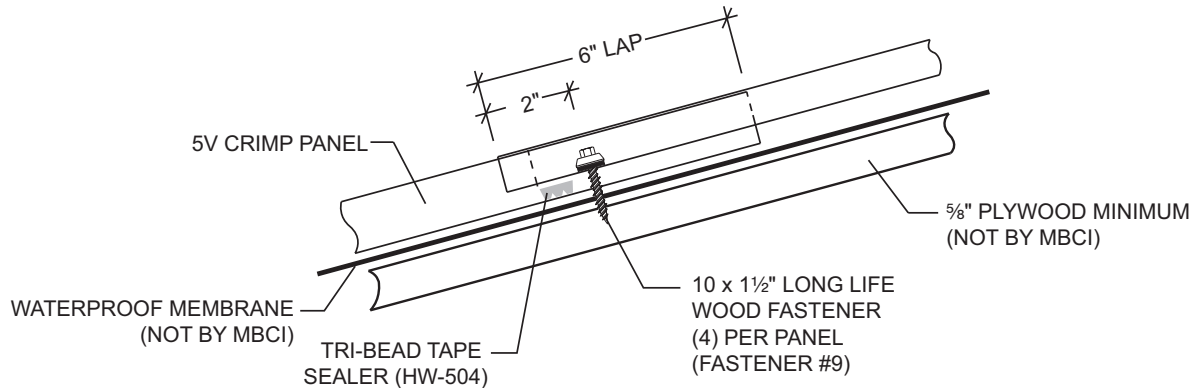

CROSS SECTION OF ENDLAP OVER WOOD DECK

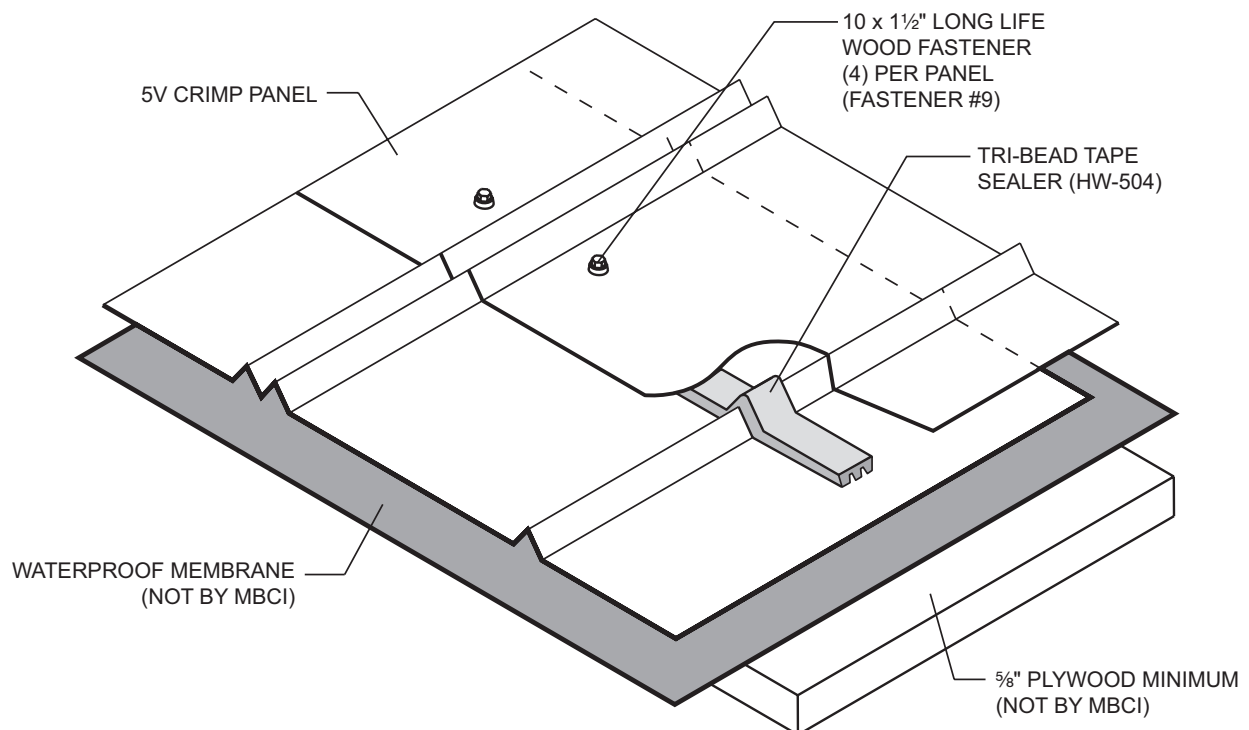

ISOMETRIC VIEW OF ENDLAP OVER WOOD DECK

NOTE:

1. Panel endlap is 6".
2. Install Tri-Bead tape sealer across width of bottom panel before installation of top panel. Top edge of tape sealer is 4 3/4" from upslope end of bottom panel.
3. Fastener pattern at endlap is shown on page V-7.

DETAILS

TYPICAL DETAILS VALLEY

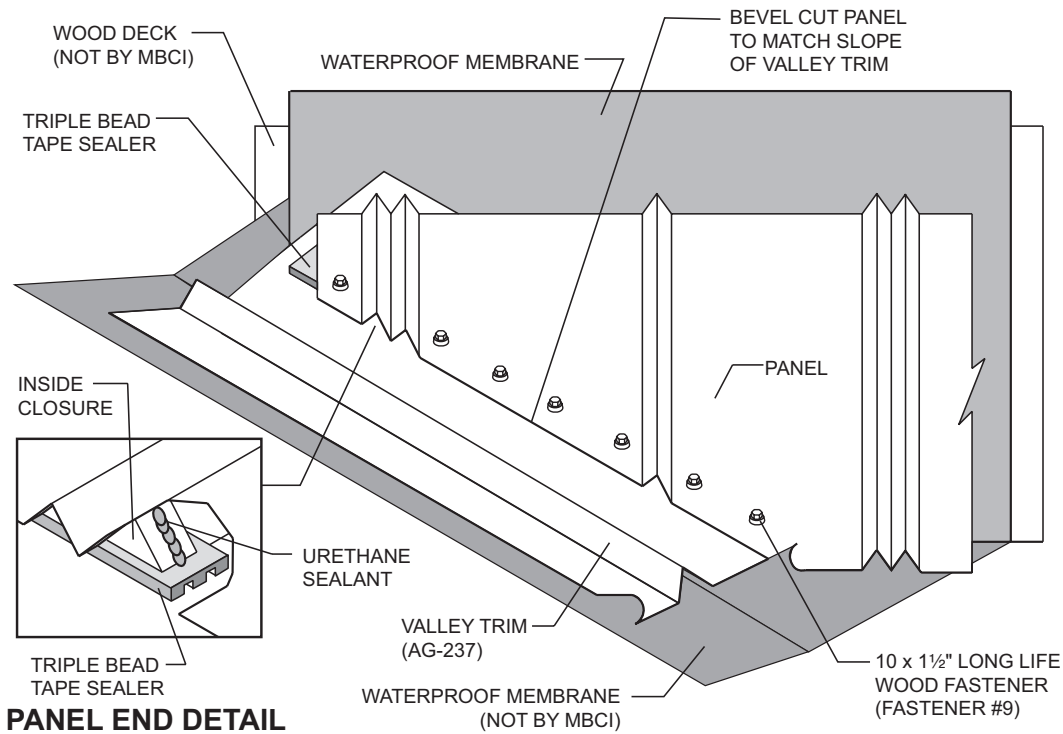
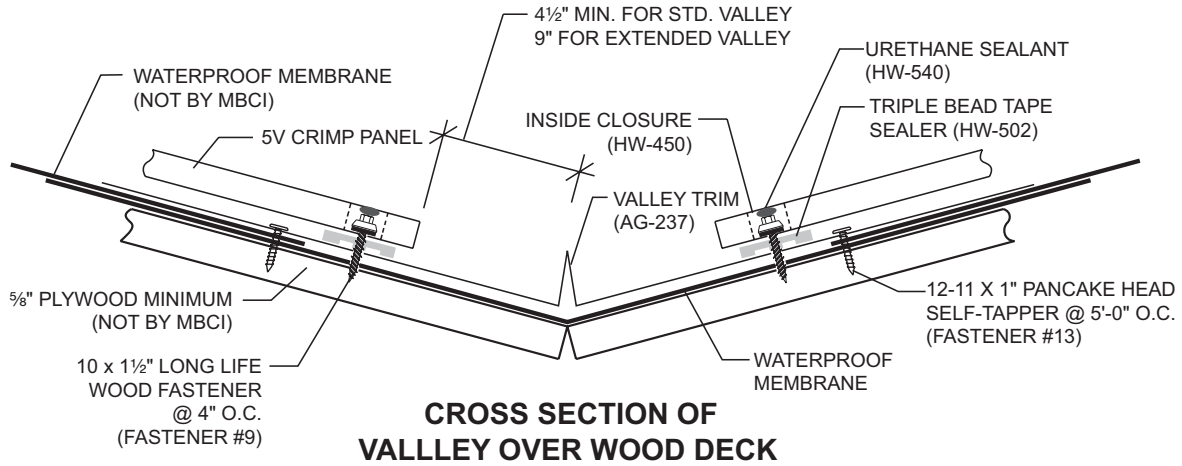

NOTE:

1. For valleys 30' or less in length, use standard valley trim. Valleys longer than 30' require extended valley trim.
2. Use waterproof membrane as a waterproof membrane in the valley area.
3. Apply Triple bead tape sealer to valley trim parallel to slope. Bottom edge of tape sealer is 1" from end of panel.
4. Bevel cut panel to match slope of valley trim.
5. Cut "V" from inside closure. Install "V" under panel and on top of Triple bead tape sealer. Install a bed of urethane sealant to top of "V".
6. Fasten panel at valley with Fastener #9 (10 x 1½" Long Life Wood Fastener) 4" O.C. maximum.

DETAILS

TYPICAL DETAILS HIP

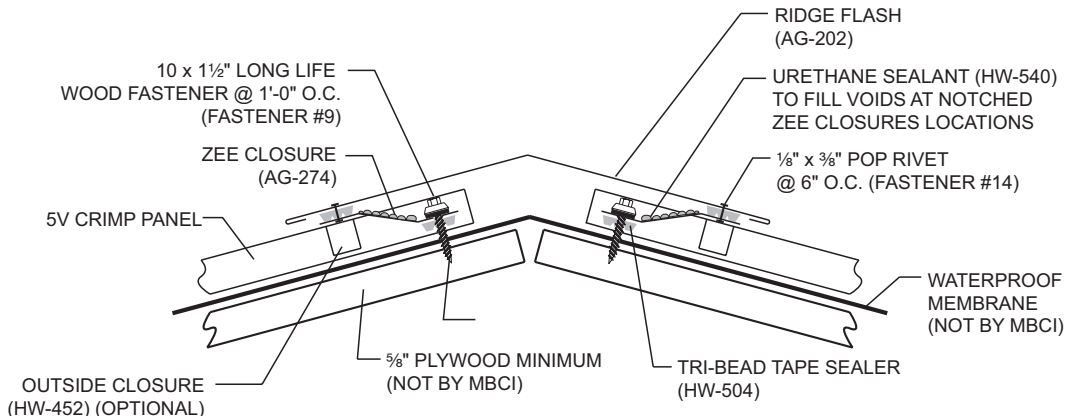

CROSS SECTION OF HIP

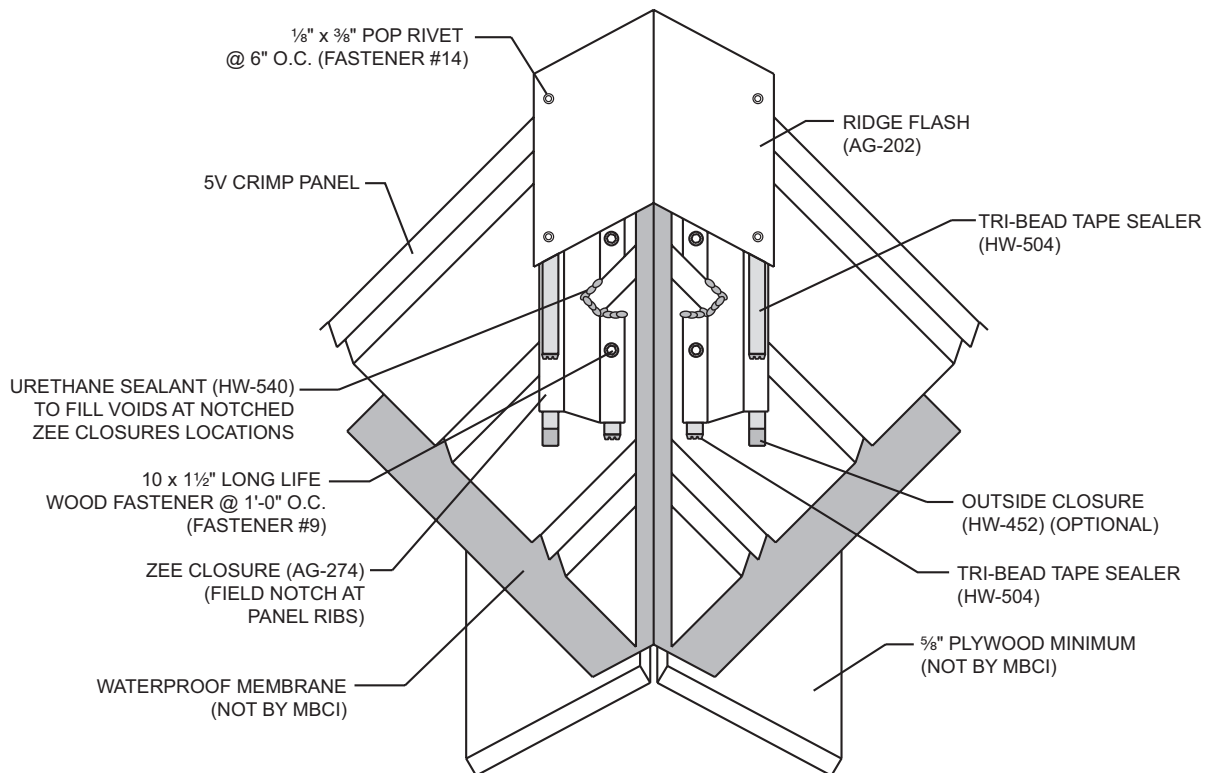

ISOMETRIC VIEW OF HIP

NOTE:

1. Bevel cut panels to match slope of hip and install.
2. Install Tri-Bead tape sealer across panels parallel to slope of hip. Top edge of tape sealer is 1½" center of hip.
3. Notch bottom flange and web of Zee closure at each "V" of the panel. Install Zee closure with Fastener #9 (10 x 1½" Long Life Wood Fastener) 1'-0" O.C. Set bottom flange of Zee closure on top of tape sealer.
4. Install Tri-Bead tape sealer to top flange of Zee closure and attach hip flash with Fastener #14A (½" x ⅜" Pop Rivet) 1'-0" O.C. **Do not attach to Panel Rib.**

DETAILS

TYPICAL DETAILS RAKE

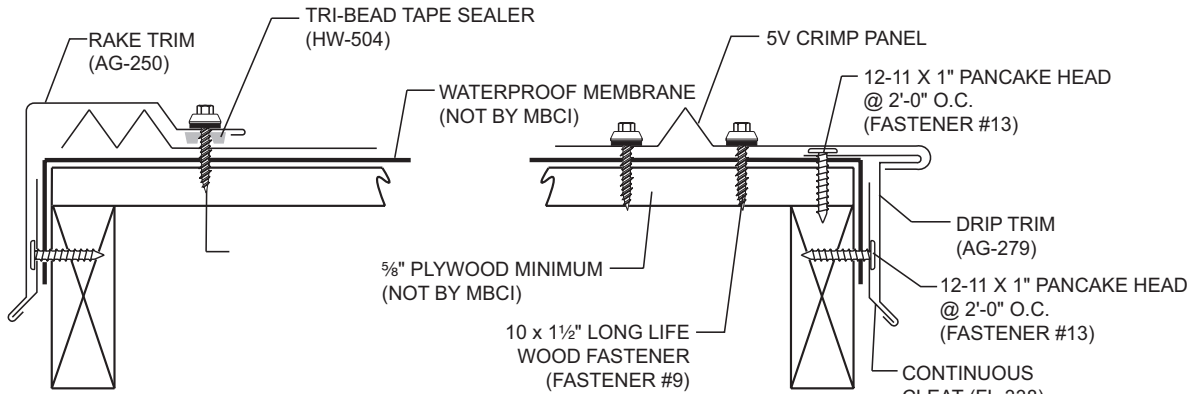

**BEGINNING/FINISHING
RAKE TRIM**

**ALTERNATE
BEGINNING/FINISHING
DRIP TRIM**

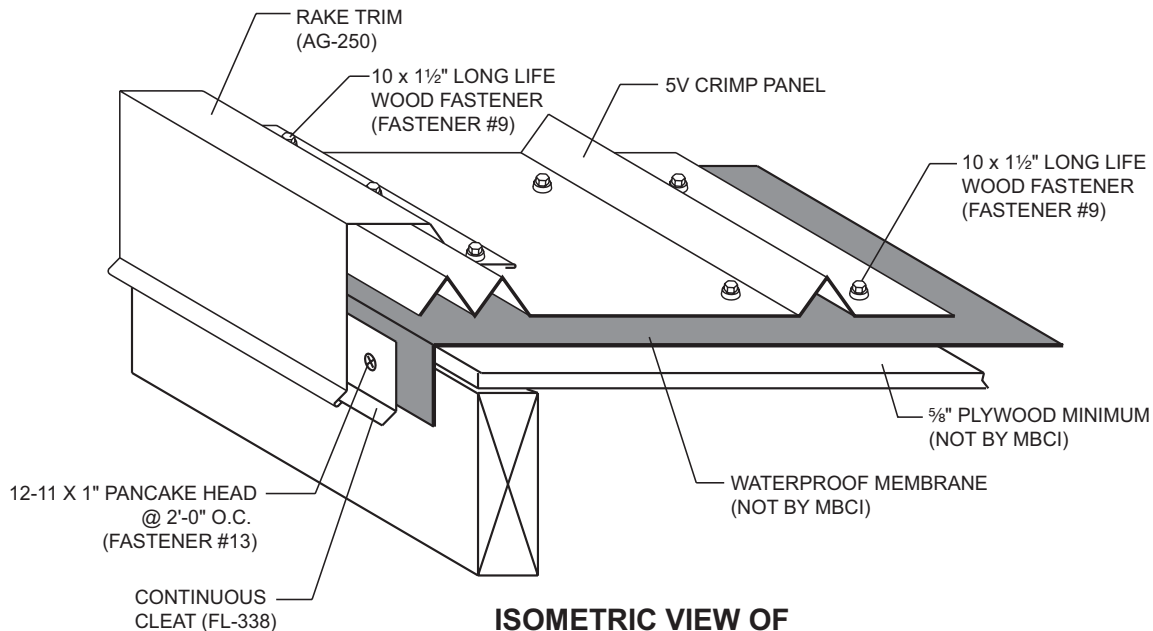

**ISOMETRIC VIEW OF
BEGINNING WITH RAKE TRIM**

NOTE:

Rake Trim

1. Install rake trim to roof panels with Fastener #9 (10 x 1½" Long Life Wood Fastener) 1'-0" O.C. Fasteners must go through Tri-Bead tape sealer.
2. When finishing off module, field bend a ½" leg up on panel before installing rake trim.

Alternate Drip Trim

1. Fasten drip trim to roof deck with Fastener #13 (10 x 1" Pancake Head) 2'-0" O.C.
2. Cut panel and bend a 1" open hem along length of panel.
3. Hook panel onto extending leg of drip trim and fasten panel to roof deck in normal manner.

DETAILS

TYPICAL DETAILS EAVE TRIM

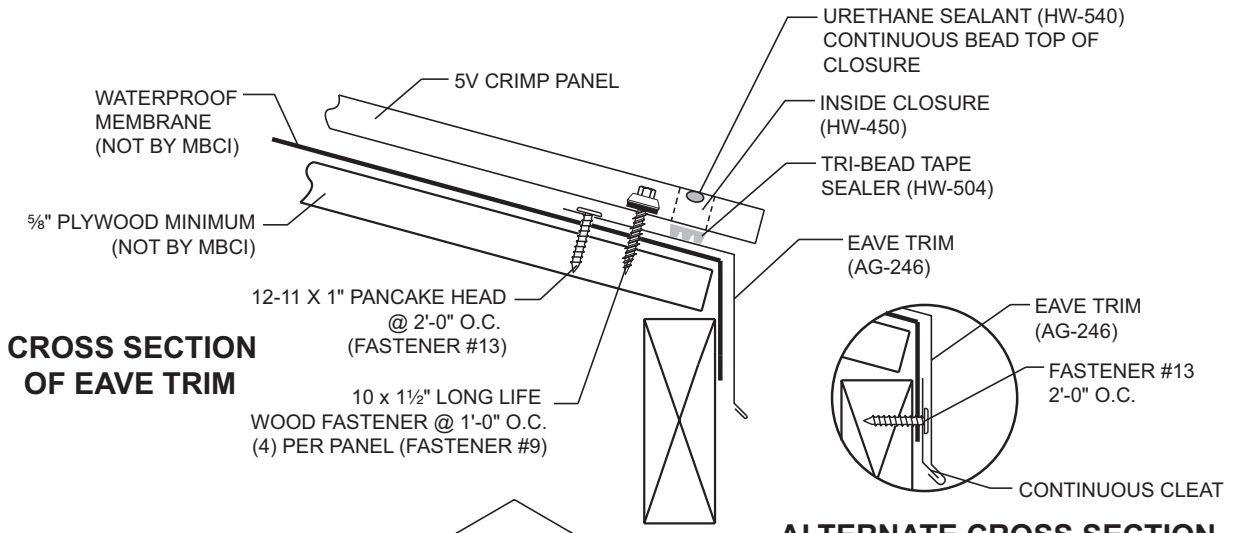

CROSS SECTION OF EAVE TRIM

ALTERNATE CROSS SECTION OF EAVE TRIM

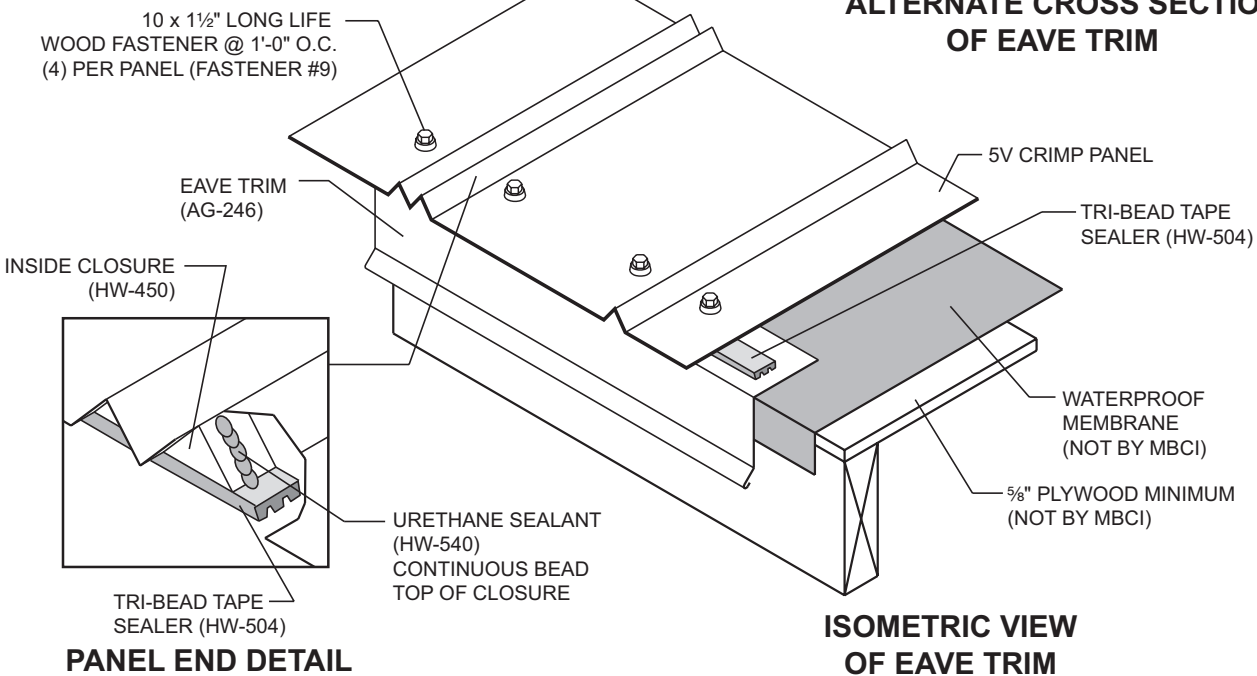

PANEL END DETAIL

ISOMETRIC VIEW OF EAVE TRIM

NOTE:

1. Attach eave trim to roof deck with Fastener #13 (10 x 1" Pancake Head) (2 fasteners per 10' section).
2. Install Tri-Bead tape sealer along top leg of eave trim. Install inside closure on top of Tri-Bead tape sealer. Apply a bead of urethane sealant to top of outside closure.
3. Attach panel at eave with Fastener #9 (10 x 1 1/2" Long Life Wood Fastener). Fastener pattern is shown on Page V-7.

DETAILS

TYPICAL DETAILS GUTTER

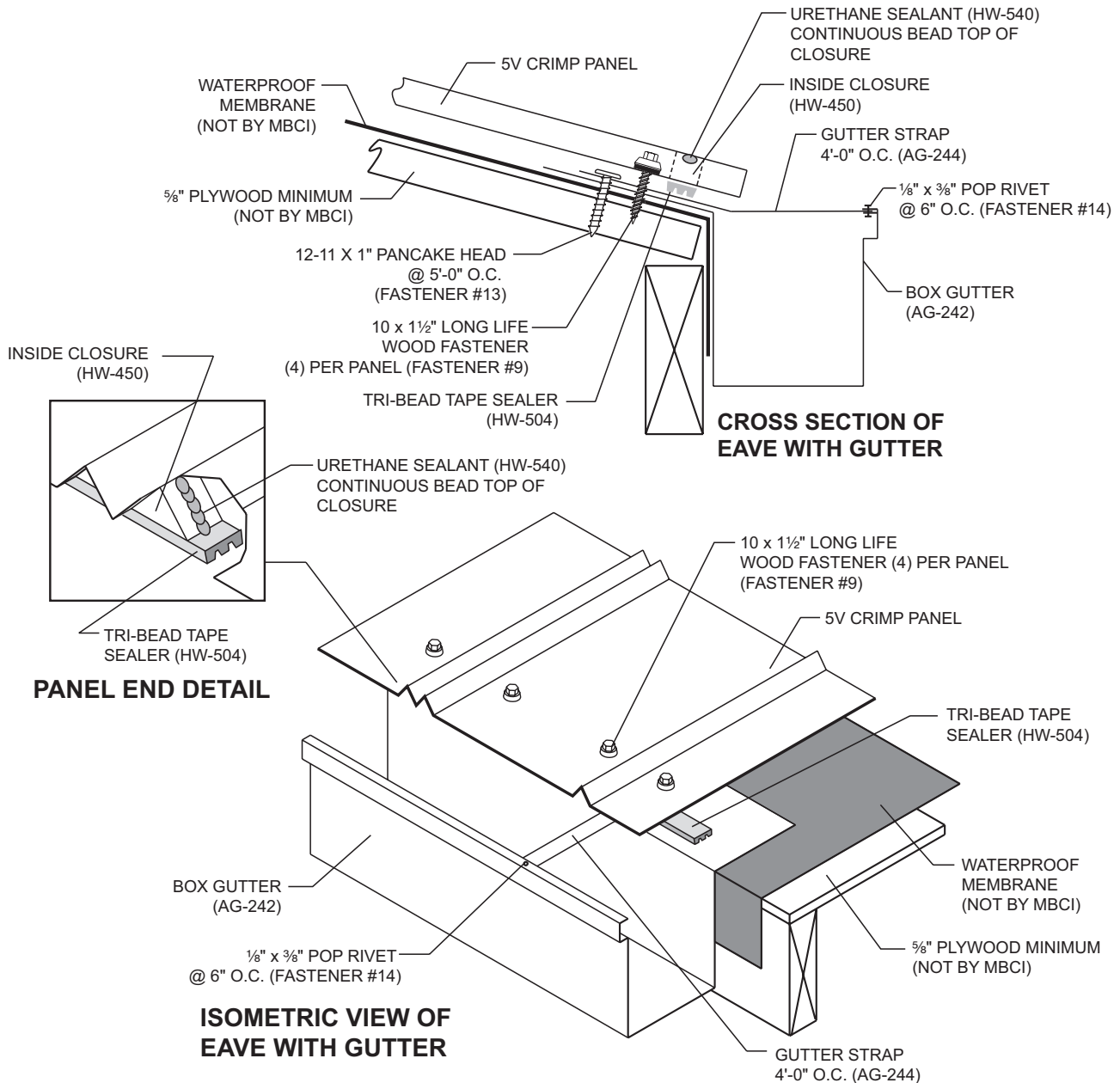

NOTE:

1. Fastener #14 (pop rivet) gutter strap to gutter 4'-0" O.C. and attach gutter to roof deck with two Fastener #13 (10 x 1" Pancake Head) per 10' section.
2. Install Tri-Bead tape sealer along top leg of gutter. Install inside closure on top of Tri-Bead tape sealer. Apply a bead of urethane sealant to top of outside closure.
3. Attach panel at eave with Fastener #9 (10 x 1 1/2" Long Life Wood Fastener). Fastener pattern is shown on Page V-7.

DETAILS

TYPICAL DETAILS SLOPE CHANGE

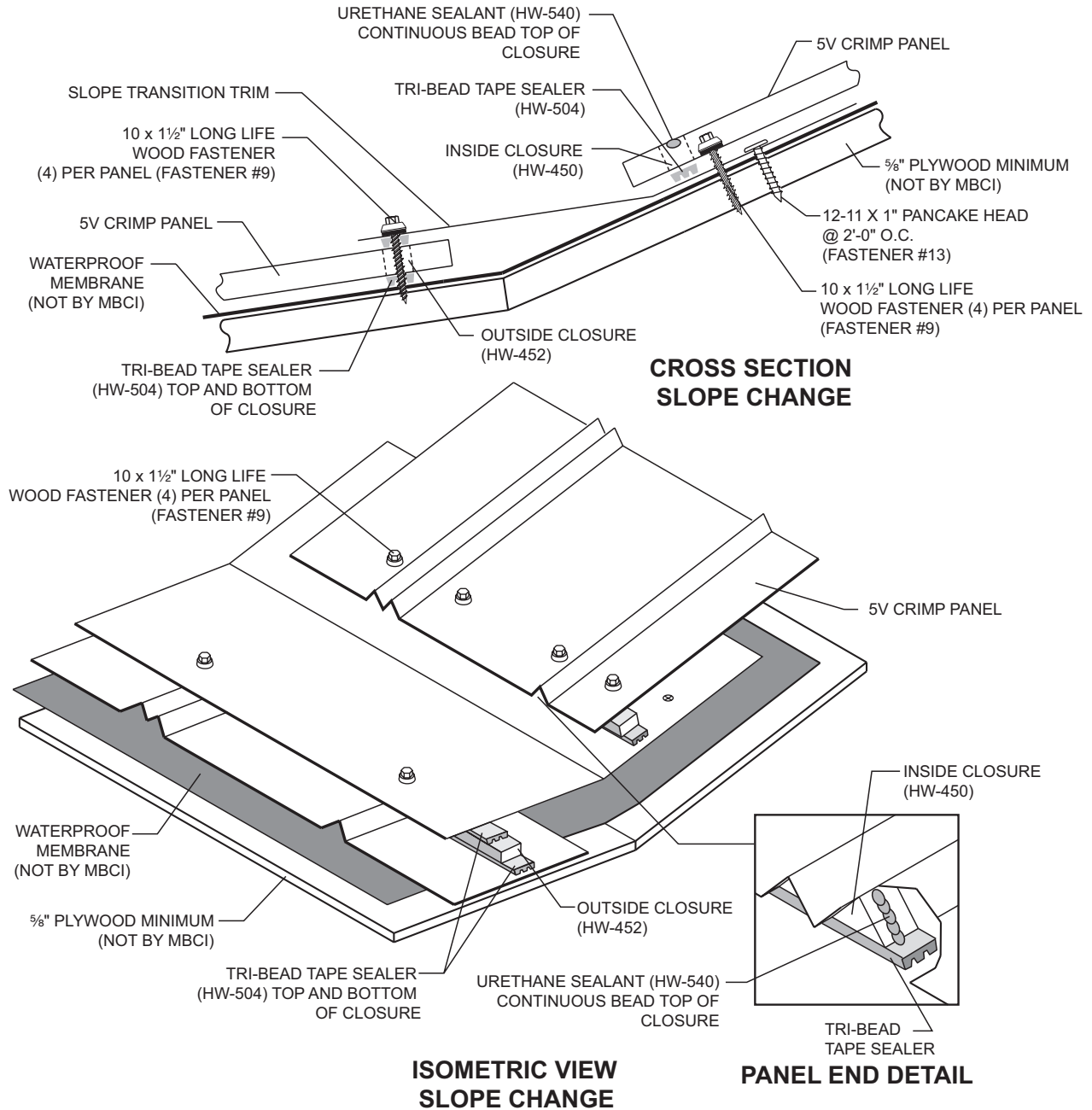

NOTE:

1. Install eave panel with Fastener #9 (10 x 1½" Long Life Wood Fastener). Apply Tri-Bead tape sealant on the bottom and top of the outside closure that is mounted down hill from the end of panel.
2. Install transition trim on top of the outside closure with hem of the trim being 1 inch from Fastener #9 (10 x 1½" Long Life Wood Fastener) that is located 1'-0" O.C. and placed in the high part of the rib.
3. Fasten down top of trim with two Fasteners #13 (10 x 1" pancake head) per 10'-0" section of trim. Place Tri-Bead tape sealant on top of trim prior to placement of inside closure. Closure should be 1" from end of panel.
4. Apply a large bead of urethane sealant to top of the inside closure prior to placing panel on top of closure.
5. Attach uphill panel with Fastener #9 (10 x 1½" Long Life Wood Fastener). Fastener pattern is shown on Page V-7.



For the most current information available, visit abcmetalroofing.com or call 877-713-6224.